

| THIRD ANGLE PROJECTION | | DOCUMENT REVISIONS | | | |
|------------------------|------------------------------------|--------------------|-------------|---------|--|
| REV | DESCRIPTION | CO NO. | DATE | CHG/CHK | |
| 1 | INITIAL RELEASE | --- | ---/---/--- | ---/--- | |
| 2 | CORRECT 12 PIN MALE CONNECTOR VIEW | 3917 | 02/02/23 | RLE/MIR | |

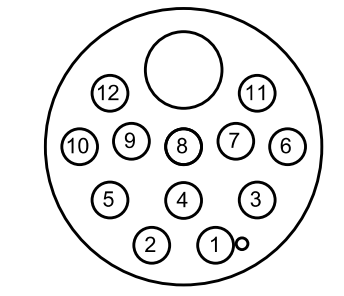

CONTACT END VIEW
12 PIN MALE

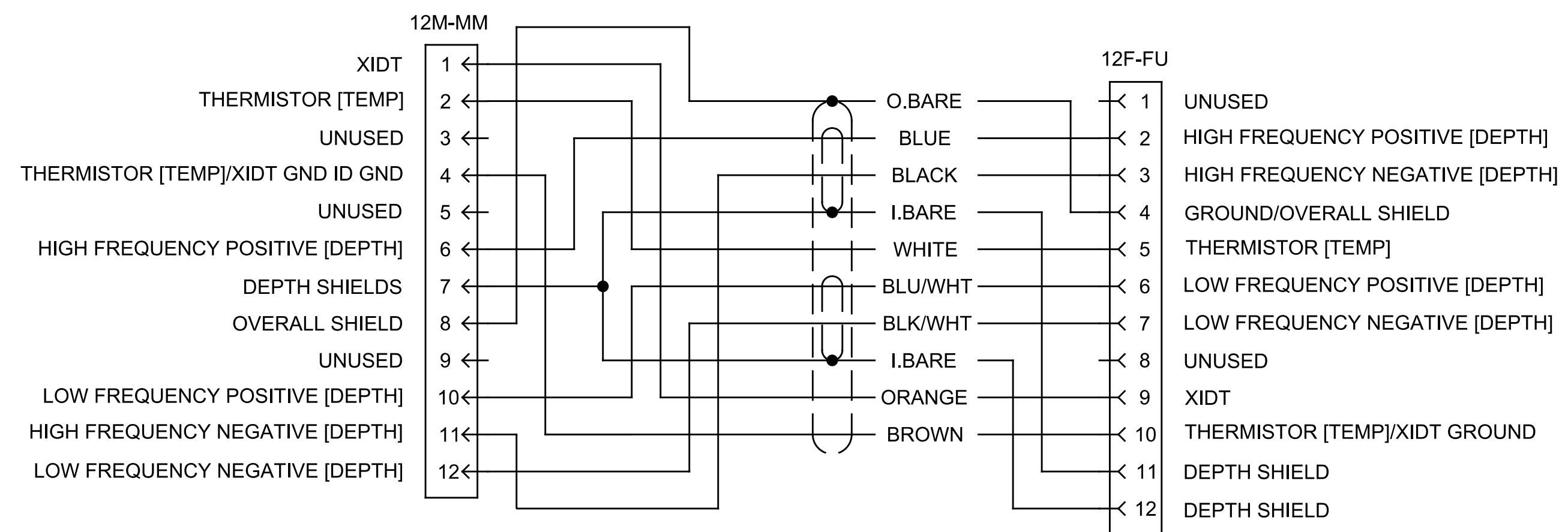
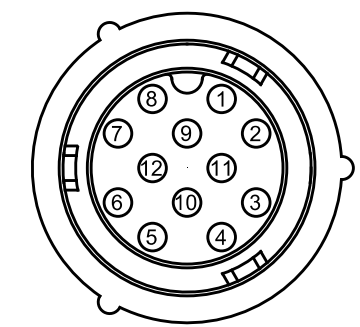

CONTACT END VIEW
12 PIN FEMALE

| | | |
|----------------------------|-----------------|----------|
| UNLESS OTHERWISE SPECIFIED | SIGNATURE | DATE |
| DIMENSIONS ARE IN INCHES | DRAWN: R.EVANS | 08/31/21 |
| TOLERANCES ON | CHECKED: I.ROBB | 09/16/21 |
| 2 PL DECIMALS: ±0.02 | | |
| 3 PL DECIMALS: ±0.005 | | |
| ANGLES: ±1/2° | | |
| FRACTIONS: ±1/16 | | |
| SURFACE FINISH: √63 | | |
| MATERIAL | | |
| AS NOTED | | |

| | | | |
|--|--------------|------------|----------------------|
| PART NUMBER | | P/N REV | |
| N/A | | N/A | |
| | | | |
| AIRMAR TECHNOLOGY CORPORATION 35 MEADOWBROOK DR MILFORD NH 03055-4613 USA TEL: 603-673-9570 FAX: 603-673-4624 | | | |
| TITLE | | | |
| WIRING, CBL ASSEMBLY, CS-CBL 12M-MM & 12F-FU | | | |
| SIZE | SCALE: NONE | DOC NUMBER | DOC REV |
| B | SHEET 1 OF 1 | D-20251 | 2 |
| CRITICAL DIMENSIONS | | (REF) | DO NOT SCALE DRAWING |

THIS DOCUMENT AND THE DATA DISCLOSED HEREIN OR HEREWITH IS NOT TO BE REPRODUCED, USED, OR DISCLOSED IN WHOLE OR IN PART TO ANYONE WITHOUT THE PERMISSION OF AIRMAR